

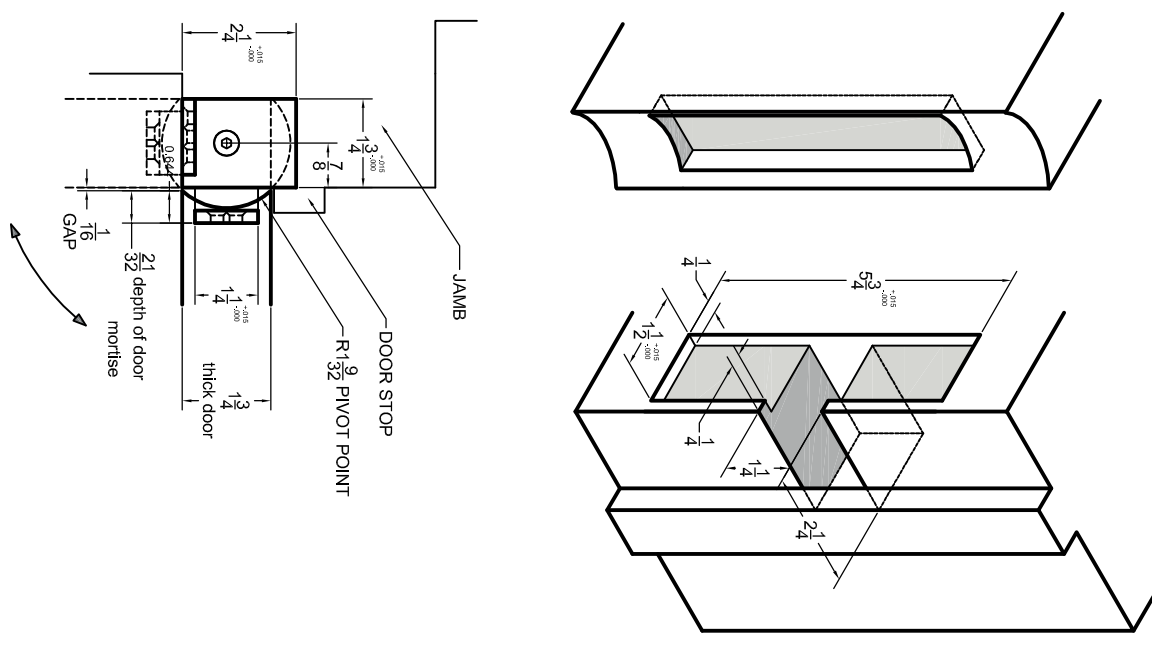

TITLE
 Harmon Hinge Template
 1 3/4" Thick Door

SIZE	DATE	SCALE
A	8/8/10	NONE

ACCURATE Template Harmon Hinge is made to conform to this drawing
 Machine Screw Size - 3/4 x 12-24 F.H
 Wood Screw Size - 1-1/4 x 12 F.H

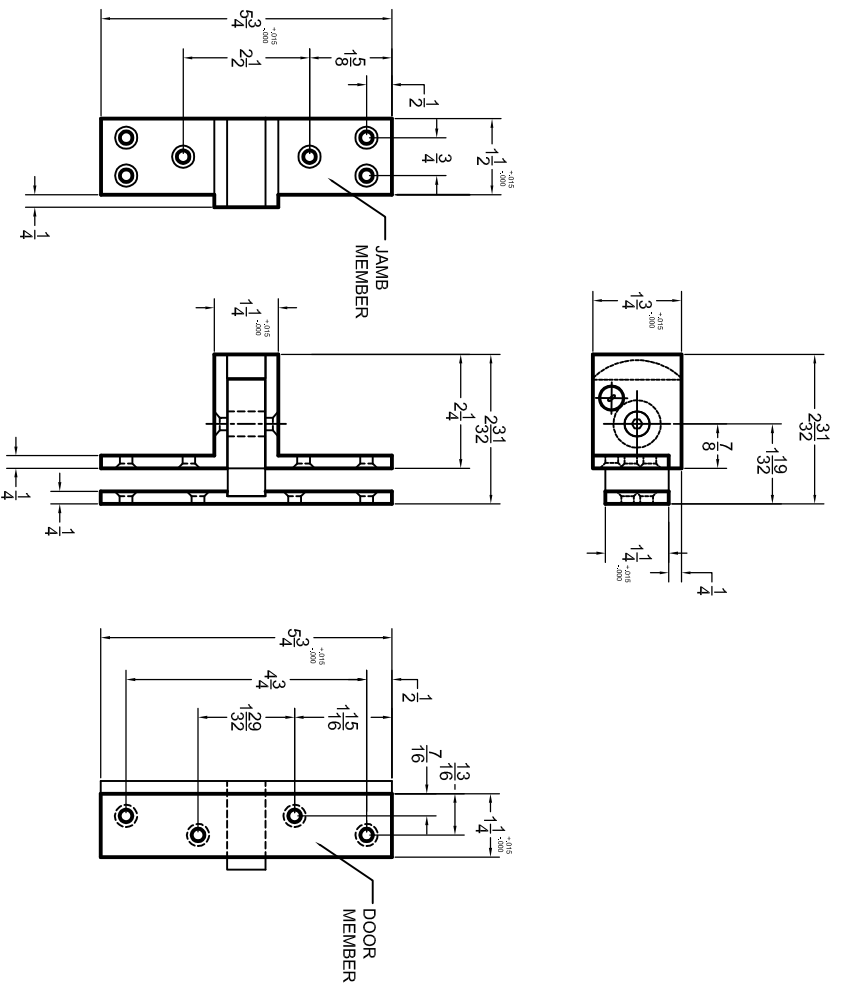

REV	DESCRIPTION	REVISIONS	BY

NOTES	APPROVAL
DWG. NO. HAR 134 temp	YIG
	REV